



Series 66 Thermostatic Water Controller Eng. No. 83010

Master water mixing valve shall be of the thermostatic type with liquid-filled motor. It shall have lead free brass body construction with replaceable corrosion-resistant components. Valve construction shall employ a sliding piston control mechanism. Piston and liner shall be of stainless steel material. Valve shall come equipped with union end stop and check inlets with removable stainless steel strainers.

Unit includes a shut-off valve, dial thermometer, union and vacuum breaker. Unit is assembled and tested with necessary fittings and nipples.

CAPACITIES – GPM SERIES 66

Pressure Drop PSI	5	10	20	30	45	60	Min. Flow GPM
Valve Number	Capacity – GPM						
66-25	9	12	17	21	25	28	4
66-50	18	25	34	41	50	57	8
66-80	28	39	54	66	80	91	12
66-125*	43	60	85	103	125	144	19
66-150*	52	72	100	124	150	174	23
66-200*	64	96	133	165	200	230	30

1/2 gpm when properly installed in recirculated system.

CAPACITIES – LPM SERIES 66

Pressure Drop PSI	5	10	20	30	45	60	Min. Flow LPM
Valve Number	Capacity – LPM						
66-25	34	45	64	79	94	106	15
66-50	68	95	129	155	189	216	30
66-80	106	148	204	250	303	344	45
66-125*	163	227	322	390	473	545	72
66-150*	197	273	379	469	568	659	87
66-200*	242	363	503	625	757	871	114

*66-125, 66-150 and 66-200 are not lead free certified

FINISH: Brass
Rough Chrome
Other

TEMP. RANGE **SET POINT**

50° to 100°F 80°F
85° to 135°F 110°F
100° to 150°F 130°F
Special _____

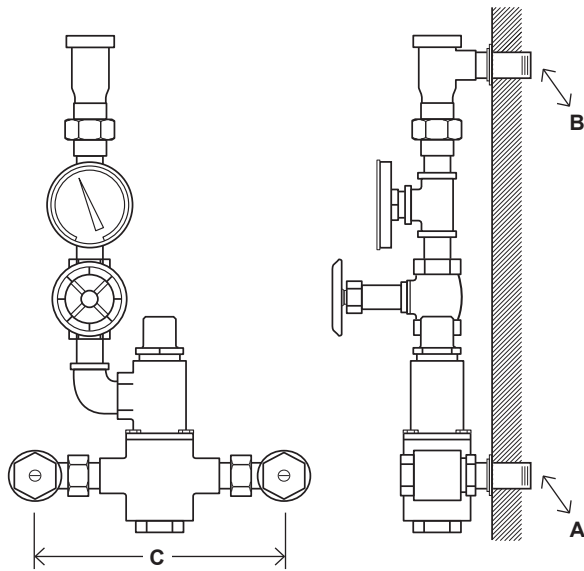

DIMENSIONS

Valve Number	A N.P.T.	B N.P.T.	C
66-25	3/4"	3/4"	10"
66-50	3/4"	1"	10"
66-80	1"	1-1/4"	11"
66-125*	1-1/4"	1-1/2"	12-3/4"
66-150*	1-1/2"	2"	13-1/4"
66-200*	2"	2"	15"

Dimensions are for reference purposes only. For rough-in dimensions please refer to Lawler's Revit/BIM models found at temperedwater.com.

*66-125, 66-150 and 66-200 are not lead free certified

**Series 66
Eng. No. 83010**

Typical Installation

Install the mixing valve below the hot water tank or heater. If this is not possible, pipe in a heat trap as shown in Figure 1 with an approximate 2' drop.

Connect a tempered water return line as shown in Figure 1. This allows flow through both ports of the mixing valve during periods of no draw.

If a dual temperature system is used, a separate recirculating loop and pump are required to return high temperature hot water to the water heater. See Figure 2.

Install an aquastat at the tempered water return pump.

Install the water heater per manufacturer's instructions.

Figure 1

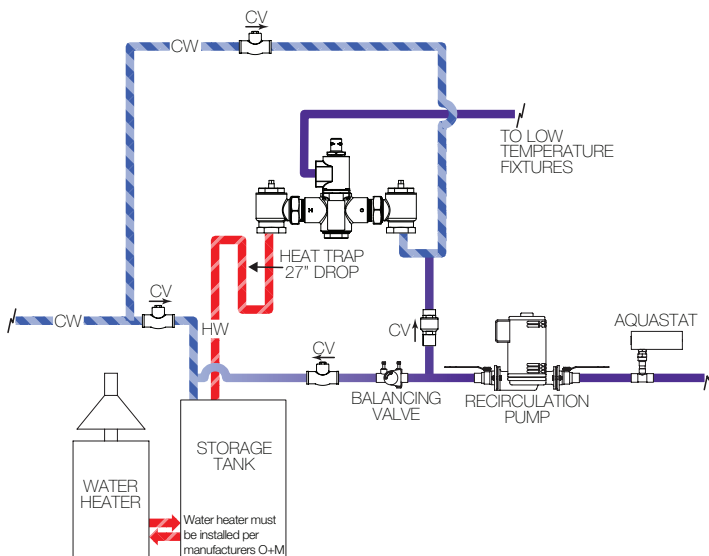

Figure 2

